

SR2 & SR3 INSULATED ROOF PANELS

GENERAL INSTALLATION GUIDE

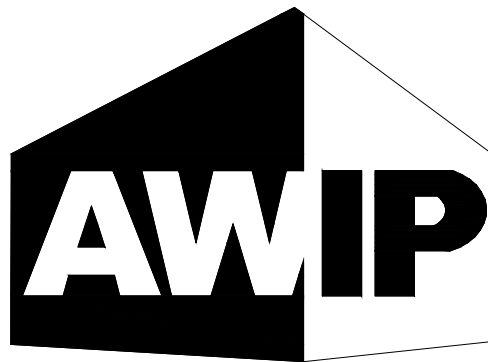

ALL WEATHER INSULATED PANELS

929 ALDRIDGE ROAD
VACAVILLE, CA 95688
PHONE: (707) 359-2280
FAX: (707) 359-2286
WWW.AWIPANELS.COM

GENERAL INSTALLATION GUIDE

HANDLING INSTRUCTIONS:

1.0 ARRIVAL ON SITE

- 1.1 ALL WEATHER INSULATED PANELS ARE CAREFULLY BUNDLED AND STRETCH WRAPPED TO PREVENT DAMAGE DURING SHIPPING. THE TRANSPORTATION COMPANY IS RESPONSIBLE FOR DELIVERING THESE COMPONENTS UNDAMAGED. FREIGHT CLAIMS SHALL BE REPORT TO AWIP IMMEDIATELY. FREIGHT CONTRACTED DIRECTLY TO CUSTOMER SHALL BE HANDLED WITH FREIGHT COMPANY.
- 1.2 WHEN SHIPMENT IS RECEIVED, CHECK EACH ITEM AGAINST THE BILL OF LADING FOR QUANTITY, LENGTH, TRANSIT DAMAGE, ETC. IF A SHORTAGE IS FOUND OR DAMAGE IS FOUND, MAKE SURE A NOTATION OF IT IS MADE ON THE BILL LADING AND SIGNED BY THE DRIVER. IT IS YOUR RESPONSIBILITY TO MAKE ANY DAMAGE CLAIM.
- 1.3 ALL WEATHER INSULATED PANELS WILL GENERALLY ARRIVE IN LARGE STRETCH WRAPPED BUNDLES ON FLAT BED TRAILERS. CONSEQUENTLY THE BUNDLES SHOULD BE UNLOADED BY MECHANICAL MEANS.

2.0 UNLOADING WITH A FORK LIFT

- 2.1 ALL BUNDLES OF PANELS ARE REINFORCED AT SPECIFIED LIFTING POINTS TO PREVENT DAMAGE WHILE LIFTING. PICK UP BUNDLES ONE AT A TIME WITH A FORK LIFT. THESE LIFTING POINTS ARE CLEARLY MARKED ON EACH BUNDLE (SEE FIG. 1). BUNDLES THAT EXCEED 20 FEET IN LENGTH HAVE TWO OR MORE LIFTING POINTS SPECIFIED. (SEE FIG. 2)
- 2.2 OVER ENGAGEMENT OF FORKS WILL CAUSE DAMAGE TO MATERIALS LOCATED ON THE OPPOSITE SIDE OF THE BUNDLE BEING LIFTED.

NOTE: EXTREME CARE SHOULD BE TAKEN TO AVOID BUMPING THE PANELS WHEN LIFTING AND MANEUVERING.

3.0 UNLOADING WITH A CRANE

- 3.1 CRANE LIFTING OF THE "INDIVIDUAL" BUNDLES SHOULD BE BY NYLON SLINGS OR SIMILAR LOCATED AT A MINIMUM OF TWO POINTS ALONG THE LENGTH OF THE BUNDLE. MULTIPLE LIFTING POINTS MAY BE REQUIRED WHEN LIFTING BY CRANE. SUITABLY STIFF INSERTS SHOULD BE LOCATED AT THE TOP AND BOTTOM OF THE BUNDLES AT THE SLING POSITIONS TO PROTECT THE EDGES OF THE UPPER AND LOWER PANELS. IF PACKS ARE LONGER THAN 15 FEET IT IS SUGGESTED THAT A PROPERLY DESIGNED AND FABRICATED LIFTING BEAM IS USED. EXTREME CARE SHOULD BE TAKEN TO AVOID BUMPING AND DROPPING OF THE BUNDLES WHEN LIFTING.
- 3.2 HOIST THE PANELS TO THE ROOF WITH THE AID OF NYLON SLINGS AND A SPREADER BAR TO PREVENT ANY CHANCE OF BENDING OR BUCKLING THE PANELS.

STANDARD LENGTH BUNDLES
10'-0" OR LONGER

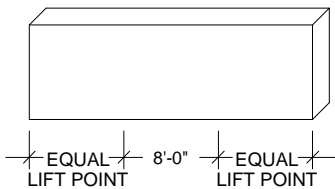

USE ONE FORKLIFT TO LIFT BUNDLES AT THE 8'-0" LIFT POINT SECTION. LIFT POINT SECTION IS BOUNDARY MARKED IN RED -- KEEP FORKS WITHIN THE MARKS.

FIGURE 1

LONG LENGTH BUNDLES
36'-0" OR LONGER

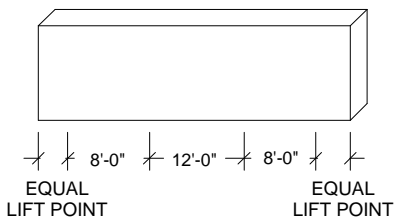

BE CAREFUL WHEN UNLOADING OR MOVING BUNDLES 36'-0" OR LONGER THAT YOU DO NOT POSITION YOUR LIFT AT THE CENTER OF THE BUNDLE. THIS WILL CAUSE PANEL DAMAGE.

USE TWO FORKLIFTS OR CRANE STRAPS TO LIFT BUNDLES AT THE 8'-0" LIFT POINT SECTIONS. LIFT POINT SECTIONS ARE BOUNDARY MARKED IN RED -- KEEP FORKS OR STRAPS WITHIN THE MARKS.

FIGURE 2

4.0 MANUALLY UNLOADING

- 4.1 ON SMALL PROJECTS UNLOADING OF THE PANELS MAY BE CARRIED OUT BY HAND.
NOTE: SPECIAL CARE SHOULD BE TAKEN WHEN HANDLING. ALWAYS LIFT THE PANELS WHEN REMOVING FROM A BUNDLE, NEVER DRAG THEM.
- 4.2 WARNING: TO PREVENT JOINT DAMAGE, NEVER LIFT THE PANEL FROM THE FLAT POSITION BY THE SIDE JOINT OR THE OVERLAPPING RIB.
- 4.3 IT IS IMPORTANT THAT WHENEVER A PANEL IS HANDLED, PICKED-UP, MOVED OR CARRIED IT SHOULD BE TURNED ON EDGE FIRST. DO NOT CARRY PANEL WHILE FLAT.

IMPORTANT NOTE: ALL PERSONNEL DOING THESE PROCEDURES MUST WEAR AT ALL TIMES THE PROPER CLOTHING, PROTECTIVE EYE WEAR AND GLOVES.

SHEET

2 OF 9

DATE: 09/08/11

DRAWN BY: CLR / JRM

SR2-SR3 INSULATED ROOF PANELS GENERAL INSTALLATION GUIDE

929 ALDRIDGE ROAD
VACAVILLE, CA 95688
PHONE: (707) 359-2280
FAX: (707) 359-2286
WWW.AWIPANELS.COM

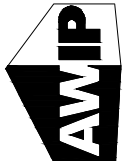

ALL WEATHER INSULATED PANELS

GENERAL INSTALLATION GUIDE continued

STORAGE INSTRUCTIONS:

5.0 SITE STORAGE

- 5.1 IF THE PANELS ARE TO BE USED IMMEDIATELY, THE BUNDLES SHOULD BE PLACED AT THE PRE-PLANNED LOCATIONS AROUND THE PERIMETER OF THE BUILDING, AS CLOSE AS POSSIBLE TO THE PLANNED WORK AREAS. REFER TO ALL WEATHER PANEL LAYOUT DRAWINGS TO DETERMINE THESE LOCATIONS. PLACE BUNDLES AS FAR PRACTICAL FROM THE SITE TO AVOID POSSIBLE DAMAGE FROM LATER SITE MANEUVERING OR UNDUE MANHANDLING.
- 5.2 IF THE BUNDLES CANNOT BE STORED IN A COVERED PLACE, IT IS NECESSARY TO CUT THE OUTSIDE PLASTIC WRAPPING AND ARRANGE THE BUNDLES IN A WAY THAT THEY ARE INCLINED AT LEAST 5% SO WATER DOES NOT ACCUMULATE, AND MOISTURE BUILD UP BETWEEN PANELS IS AVOIDED. THE CUT SHOULD BE MADE ON THE SIDE OF THE BUNDLE AND BE CONTINUOUS. (SEE FIG. 3 BELOW)
- 5.3 BUNDLES SHOULD BE STACKED NO MORE THAN TWO HIGH AND THE FOAM STICKERS FOR THE UPPER BUNDLE SHOULD BE LOCATED IN LINE WITH THE FOAM STICKERS IN LINE WITH THE LOWER BUNDLE (SEE FIG. 3).
- 5.4 IDEALLY THE BUNDLES SHOULD BE STORED UNDER A TEMPORARY SHELTER WITH THE PLASTIC REMOVED FROM THE TOP AND SIDES OF THE BUNDLE. SITE STORAGE TIME SHOULD BE MINIMIZED.
- 5.5 IF SHELTER IS NOT AVAILABLE, OUR PANELS ARE PACKAGED WITH PLASTIC STRETCH WRAP AND EXPANDED POLYSTYRENE BOARD. IT IS HOWEVER, A REQUIREMENT THAT ADDITIONAL WATERPROOF PROTECTION BE PROVIDED TO PROTECT THE PANELS FROM WET WEATHER CONDITIONS IN TRANSIT AND AT THE JOBSITE. STANDING WATER ON STORED AND OR BUNDLED SKIDS MAY CAUSE DAMAGE TO THE PANEL FINISH AND IS NOT ACCEPTABLE.
- 5.6 ELEVATE ONE END OF BUNDLES (SEE FIG. 3) DO NOT STORE FOR LONGER THAN 30 DAYS. MOISTURE BETWEEN PANELS CAN CAUSE CORROSION AND OXIDATION OF PAINTED SURFACES CAN OCCUR. DO NOT STAND PANELS ON EDGE OF JOINT NARY OR SAW CUT EDGE. NEVER STORE OR HANDLE PANELS IN A HORIZONTAL POSITION.
- 5.7 BUNDLES SHOULD BE FIRMLY TIED OR WEIGHTED DOWN WHEN BROKEN OPEN FOR USE.

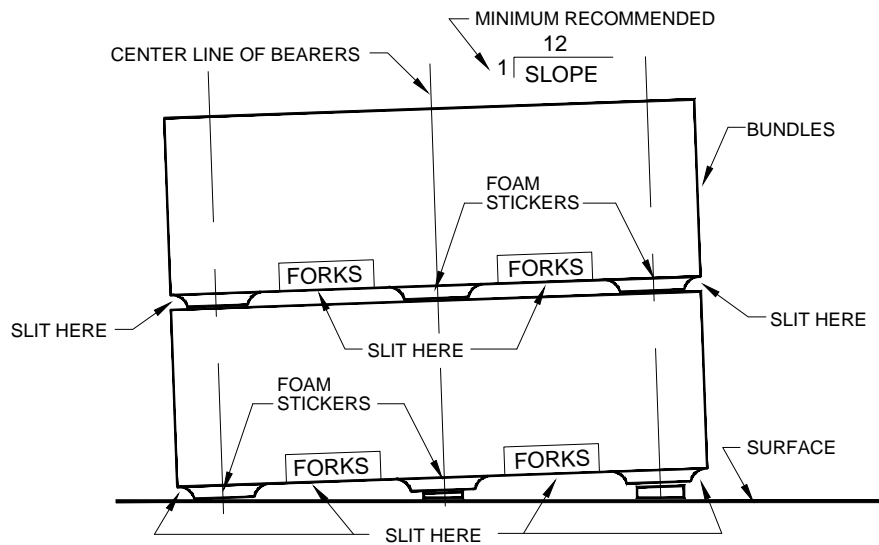

FIGURE 3

6.0 ACCESSORIES AND AUXILIARY ITEMS

- 6.1 DUE CARE SHOULD BE AFFORDED TO THE UNLOADING AND STORAGE OF SMALL ITEMS, i.e. FLASHINGS, FASTENERS, SEALANTS, ETC., THAT ARRIVE ON SITE FOR INCLUSION IN THE WORK.
- 6.2 COVER ALL PALLET CRATES OR BOXES TO PROTECT MATERIALS FROM WEATHER BUT ALLOW FOR VENTILATION TO PREVENT COLLECTION OF CONDENSATION.

7.0 STRUCTURAL SUPPORTING STEEL

- 7.1 FOR QUALITY PANEL INSTALLATION THE PANEL CONTRACTOR SHALL EXAMINE THE ALIGNMENT OF THE STRUCTURAL STEEL BEFORE INSTALLATION OF THE ROOF PANELS. THE STEEL SHALL BE ALIGNED TO THE TOLERANCES ESTABLISHED IN THE AISC CODE OF STANDARD PRACTICE, SECTION 7, AND THE SUPPLEMENT MODIFICATION CONTROL SECTION 7.11.3, ADJUSTABLE ITEMS. THE MAXIMUM DEVIATION OF STEEL ALIGNMENT SHOULD BE LIMITED TO (-0 +1/2") FROM THE CONTROL WITH A 1/8" MAXIMUM CHANGE IN DEVIATION FOR ANY MEMBER OF ANY 10'-0" RUN OF PANEL.
- 7.2 ANY VARIANCES FROM THESE TOLERANCES CAN AFFECT BOTH PERFORMANCE AND ESTHETICS MUST BE REPORTED TO THE ARCHITECT AND GENERAL CONTRACTOR AND CORRECTED BY THE GENERAL CONTRACTOR OR ACCEPTED, IN WRITING, BY THE ARCHITECT BEFORE ROOF PANEL INSTALLATION PROCEEDS.

SHEET

3 OF 9

DATE: 09/08/11

DRAWN BY: CLR / JRM

SR2-SR3 INSULATED ROOF PANELS
GENERAL INSTALLATION GUIDE

929 ALDRIDGE ROAD
VACAVILLE, CA 95688
PHONE: (707) 359-2280
FAX: (707) 359-2286
WWW.AWIPANELS.COM

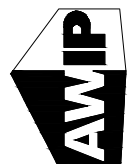

ALL WEATHER INSULATED PANELS

GENERAL INSTALLATION GUIDE continued

8.0 PROTECTIVE PLASTIC FILM

- 8.1 ALL WEATHER INSULATED PANELS AND METAL TRIMS HAVE A TEMPORARY PROTECTIVE PLASTIC FILM. THIS PLASTIC FILM HELPS PREVENT DAMAGE IN SHIPPING AND HANDLING.
- 8.2 THIS PROTECTIVE PLASTIC FILM IS NOT TO BE REMOVED UNTIL PANEL AND METAL TRIMS ARE READY FOR ERECTION ON JOB.
- 8.3 PROTECTIVE PLASTIC FILM IS NOT TO BE EXPOSED TO DIRECT SUN FOR MORE THAN 48 HOURS. THIS MAY CAUSE THE PLASTIC FILM TO BOND TO THE METAL PANEL FACE AND MAY BE MORE DIFFICULT TO REMOVE. ADDITIONALLY, PROLONGED EXPOSURE TO TEMPERATURES ABOVE 80°F IS NOT RECOMMENDED AS IT MAY CAUSE THE PEEL COAT TO LEAVE AN ADHESIVE RESIDUE ON THE PANEL FACING(S). THEREFORE, IT IS VERY IMPORTANT TO FOLLOW SECTION 5.0 INSTRUCTIONS AND STORE THE PANELS AND ACCESSORIES IN A DRY, COVERED PLACE.
- 8.4 REMOVE THE PROTECTIVE PLASTIC FILM FROM THE PANEL CORNER AND PULL OFF AT A 45° ANGLE. THIS IS THE BEST WAY TO REMOVE THE FILM. (SEE FIG. 4)
- 8.5 THE PLASTIC MUST BE REMOVED FROM BOTH PANEL FACES IF APPLICABLE AND METAL TRIMS.
- 8.6 IF THE METAL FACES REMAINS STICKY AFTER THE PLASTIC IS REMOVED, CLEAN WITH A SOFT CLOTH AND WATER. IT MAY BE NECESSARY TO USE A CITRUS BASED CLEANING SOLUTION ADDED TO THE WATER IN A SUFFICIENT DILUTION RATIO TO EFFECT COMPLETE REMOVAL OF THE ADHESIVE.

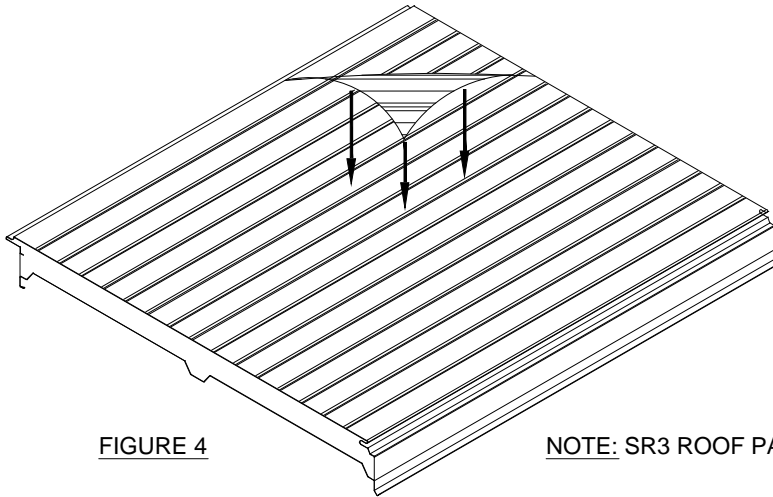

FIGURE 4

NOTE: SR3 ROOF PANEL SHOWN

9.0 ACCESSORIES, TRIM, SEALANTS, ECT.

- 9.1 BE EXTREMELY CAREFUL TO UNLOAD AND STORE THE SHEET METAL SCREWS, SEALANTS, ECT. IT IS IMPORTANT TO GUARD AGAINST DAMAGE OR MISPLACEMENT OF THE ACCESSORIES.
- 9.2 ALL THESE ACCESSORIES MUST BE STORED IN A COVERED PLACE ON THE JOBSITE NOT EXPOSED TO THE ELEMENTS.

10.0 PANEL CUTTING PROCEDURES

- 10.1 PANELS MAY BE CUT PRIOR TO INSTALLATION OR CUT IN PLACE. ALL WEATHER INSULATED PANELS RECOMMENDS CUTTING THE PANELS PRIOR TO INSTALLATION TO MINIMIZE PANEL DAMAGE AND TO INSURE A BETTER FIT.
- 10.2 ALL WEATHER INSULATED PANELS RECOMMENDS THE USE OF A TRUMPF TPC 150-2 PANEL CUTTER OR MILWAUKEE 6370-21 CIRCULAR SAW WITH A 8" DIAMETER 40 TOOTH CARBIDE BLADE.

TO PERFORM A GOOD CUT, FOLLOW STEPS 10.3 TO 10.6 SHOWN BELOW. IF THE PANEL THICKNESS IS GREATER THAN THE SAW'S BLADE RADIUS, CUTTING SHOULD BE DONE IN TWO STEPS, CUTTING ONE SIDE AT A TIME, FOLLOW STEPS 10.3 TO 10.9.

NOTE: DO NOT USE A RECIPROCATING SAW AS FRICTION BETWEEN THE CUTTING BLADE AND THE PANEL CREATES HEAT, DAMAGING THE PAINTED SURFACE OF THE PANEL.

SHEET

DATE: 09/08/11

DRAWN BY:
CLR / JRM

4 OF 9

SR2-SR3 INSULATED ROOF PANELS GENERAL INSTALLATION GUIDE

929 ALDRIDGE ROAD
VACAVILLE, CA 95688
PHONE: (707) 359-2280
FAX: (707) 359-2286
WWW.AWIPANELS.COM

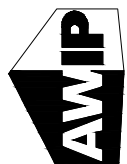

ALL WEATHER INSULATED PANELS

GENERAL INSTALLATION GUIDE continued

- 10.3 MEASURE THE DISTANCE OR AREA TO CUT AND MARK A LINE ON THE PANEL SURFACE.
- 10.4 USE ADHESIVE TAPE ON BOTH SIDES OF THE CUTTING LINE TO PROTECT PANEL SURFACE.
- 10.5 RECHECK MEASUREMENTS AND PROCEED WITH CUTTING OPERATION.
- 10.6 CLEAN OFF ANY METAL CHIPS LEFT ON PANEL AFTER CUTTING PROCEDURE. IF ANY METAL CHIPS REMAIN IN THE FOAM, THESE CAN BE REMOVED BY HAND.
- 10.7 IF NECESSARY, TURN PANEL OVER AND FOLLOW THE SAME STEPS ON THIS SIDE OF THE PANEL.
- 10.8 CUT FOAM BETWEEN METAL SHEETS USING A SHARP KNIFE. ALL ROOF ENDLAP CUTBACKS AND EAVE CUTBACKS ARE TO BE FIELD REMOVED. TAKE CARE TO REMOVE ALL FOAM FROM UNDERSIDE, ROOF ENDLAPS PRIOR TO INSTALLING.
- 10.9 FILE OR SAND OFF ANY BURRS ON THE METAL AFTER CUTTING. THE PANEL IS NOW TO BE INSTALLED; THE INSTALLER MUST CONSIDER PERFORMING THERMAL BREAKS PRIOR TO INSTALL AND A CONTINUOUS APPLICATION OF BEAD OF SEALANT ALONG THE INSIDE OF THE FEMALE JOINT (WARM SIDE) SUCH TASK SHALL BE DONE ON GROUND.

ROOF PANEL INSTRUCTIONS:

11.0 ROOF PANEL INSTALLATION SEQUENCE

- 11.1 SR2 AND SR3 ROOF PANELS MUST BE INSTALLED IN A SPECIFIC SEQUENCE. THIS ENSURES THE CORRECT LAPPING OF THE SIDE AND END LAPS. (REFER TO FIG. 5) FOR THE CORRECT INSTALLATION SEQUENCE. THE PANEL NUMBERS CORRESPOND TO THEIR ORDER OF INSTALLATION.
- 11.2 **IMPORTANT NOTE:** AS "EACH" PANEL IS INSTALLED ALL MAIN FASTENING AND SIDE LAP FASTENING SHOULD BE CARRIED OUT. THIS IS ESPECIALLY IMPORTANT ON HR3 AND HR5 ROOF PANELS AND WILL ENSURE THAT UNNECESSARY BACK TRAFFICKING OVER THE ROOF IS AVOIDED. READ NOTE 12.9 UNDER HEADING 12.0 INSTALLATION STEPS

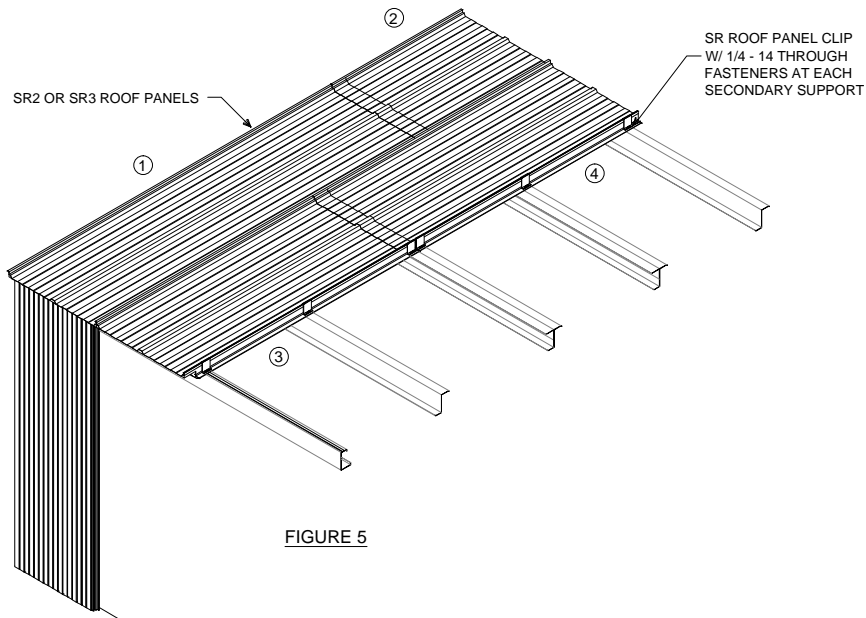

FIGURE 5

12.0 INSTALLATION STEPS

- 12.1 AS EACH INDIVIDUAL PANEL IS REMOVED FROM THE PACK, THE MALE AND FEMALE EDGES SHOULD BE VISUALLY EXAMINED AND ANY SLIGHT OVER SPILL OF INSULATION SHOULD BE CAREFULLY REMOVED.
- 12.2 THE FIRST SR2 OR SR3 PANEL TO BE INSTALLED CAN HAVE THE OVERLAPPING STANDING RIB EDGE CUT BACK OR NOT.
- 12.3 THE ROOF PANEL SHOULD BE LAID FLUSH WITH THE FACE OF THE WALL PANEL AS SHOWN ON PANEL DETAIL DRAWINGS IT IS IMPORTANT THAT THE FIRST TIER OF PANELS ARE LAID TRUE TO LINE, PROPERLY LINED WITH A STRING TO ENSURE A TRUE AND NEAT RUN.
- 12.4 THE STARTER PANEL SHOULD BE FASTENED AS SHOWN ON PANEL DETAIL DRAWINGS. THE PANEL SHOULD BE FASTENED AT EACH PURLINE AT THE RAKE EDGE.
- 12.5 A 1/8" x 1/2" WIDE STRIP OF BUTYL TAPE SEALANT SHOULD BE PLACED ON THE STANDING SEAM STARTER PANEL TO BE OVERLAPPED.
- 12.6 SQUARE EACH PANEL BEFORE INSTALLING FASTENERS. PRIOR TO INSTALLING, PANELS MAY NEED TO BE SHADED TO PREVENT EXCESSIVE THERMAL BOW WHICH MAY HINDER PANEL ENGAGEMENT.
- 12.7 IF PREDRILLING IS REQUIRED USE THE DRILL BIT SIZES LISTED BELOW.

<u>MATERIAL</u>	<u>FASTENER TYPE</u>	<u>DRILL</u>
18 GA. - 16 GA.	#14 HEX HEAD TEK 3 SELF-DRILLING SCREW W/ SEAL WASHER	5/32" PILOT
14 GA.	#14 HEX HEAD TEK 3 SELF-DRILLING SCREW W/ SEAL WASHER	3/16" PILOT
12 GA. - 11 GA.	#14 HEX HEAD TEK 3 SELF-DRILLING SCREW W/ SEAL WASHER	# 3 DRILL
3/16" TO 3/8"	#14 HEX HEAD TEK 3 SELF-DRILLING SCREW W/ SEAL WASHER	# 1 DRILL
3/8" & HEAVIER	#14 HEX HEAD TEK 3 SELF-DRILLING SCREW W/ SEAL WASHER	.231" PILOT

SHEET

5 OF 9

DATE: 09/08/11

DRAWN BY: CLR / JRM

**SR2-SR3 INSULATED ROOF PANELS
GENERAL INSTALLATION GUIDE**

929 ALDRIDGE ROAD
VACAVILLE, CA 95688
PHONE: (707) 358-2280
FAX: (707) 358-2286
WWW.AWIPANELS.COM



ALL WEATHER INSULATED PANELS

GENERAL INSTALLATION GUIDE continued

- 12.8 AFTER APPLYING THE 3/8" X 3/32" BUTYL TAPE SEALANT ON TOP OF THE LEADING 90 DEGREE FORMED LONGITUDINAL MALE EDGE, INSTALL THE THERMALLY BROKEN STAINLESS STEEL SR JOINT CLIP AS SHOWN IN FIGURE 6. APPLY ANOTHER STRIP OF BUTYL TAPE ON TOP OF THE CLIP EXTENDING IT 1" BEYOND THE CLIP ENDS. PANEL TO BE FASTENED PER THE ROOF PANEL FASTENING SCHEDULE AND CALCULATIONS. FASTENER REQUIREMENTS ARE BASED ON DESIGN LOADS SPECIFIC TO THE PROJECT. CONSULT AN ALL WEATHER INSULATED PANELS' REPRESENTATIVE OR FACTORY FOR ALLOWABLE PANEL AND FASTENER DESIGN LOADS. USE A 600 RPM ELECTRIC SCREW GUN TO DRIVE FASTENERS. DO NOT USE IMPACT TOOLS AS THESE DEVICES WILL OVER TIGHTEN AND CAUSE DAMAGE.
- 12.9 THE FASTENING PATTERN TO USE WILL DEPEND ON THE PANEL THICKNESS, SPAN AND DESIGN LOADS. CONSULT YOUR ALL WEATHER INSULATED PANEL REPRESENTATIVE OR THE FACTORY FOR THE CORRECT PATTERN & SCREW SIZES.
- 12.10 NEST THE NEXT PANEL INTO PLACE BY PUSHING IT INTO THE LINER SIDE TONGUE AND GROOVE. THE OVERLAPPING FEMALE EDGE SHOULD NOW BE ALIGNED OVER THE FASTENED PANEL'S LEADING MALE EDGE WITH THE CLIPS SANDWICHED BETWEEN THE FOAM AND METAL EDGES.
- 12.11 FOLLOW SR SERIES STANDING SEAM ELECTRIC SEAMER AND HAND SEAMER MANUALS TO SEAM JOINTS TO A 90° BEND. TO PREVENT THE POSSIBILITY OF PANELS BEING WIND DAMAGED OR BLOWN OFF THE ROOF, IT IS HIGHLY RECOMMENDED THAT SEAMING IS COMPLETED AS SOON AS POSSIBLE. THIS WILL ENSURE THAT THE ROOF ASSEMBLY IS ADEQUATELY SECURED DURING INSTALLATION.

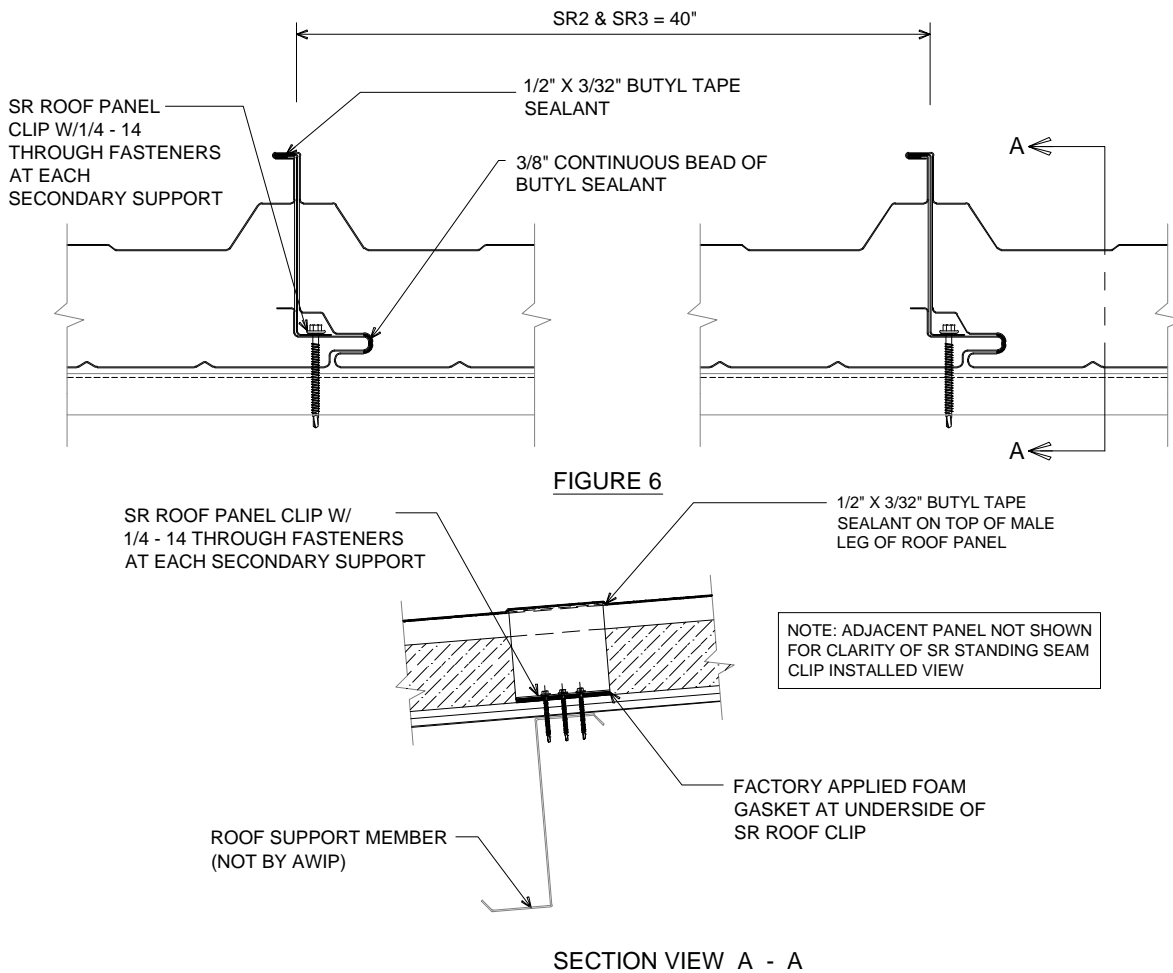

- 12.12 AFTER DRILLING OR CUTTING PANELS, ALWAYS REMOVE METAL CHIPS & FOAM DUST THAT HAS FALLEN ON FLASHINGS OR PANELS.
- 12.13 IF THE ROOF SYSTEM CONSIST OF ONE ROW OF PANELS, THEN PROCEED TO THE NEXT PANEL AND REPEAT STEPS 12.5 THRU 12.13 UNTIL THE ROOF IS COMPLETE. IF THE SLOPE CONSIST OF MORE THAN ONE ROW OF PANELS DO NOT FASTEN THE PANELS TO THE STEEL SUPPORTS AT THE END LAP AND REFER TO SECTION 13.0 FOR SR2 AND SR3 ROOF PANEL END LAP FASTENING.
- 12.14 AFTER ALL PANELS ARE INSTALLED, FASTEN THE EAVE, RAKE AND PEAK TRIM RESPECTIVELY. THE TRIM SHOULD BE FASTENED AS SHOWN IN THE ARCHITECTURAL DETAILS.

SHEET

DATE: 09/08/11

DRAWN BY: CLR / JRM

6 OF 9

**SR2-SR3 INSULATED ROOF PANELS
GENERAL INSTALLATION GUIDE**

929 ALDRIDGE ROAD
VACAVILLE, CA 95688
PHONE: (707) 358-2280
FAX: (707) 358-2286
WWW.AWIPANELS.COM

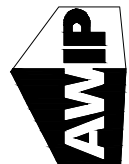

ALL WEATHER INSULATED PANELS

GENERAL INSTALLATION GUIDE continued

13.0 ROOF PANEL END LAP FASTENING

- 13.1 WHEN THE ROOF SLOPE CONTAINS MORE THAN ONE ROW OF PANELS THE FOLLOWING STEPS SHOULD BE OBSERVED IN THE FASTENING OF THE PANEL END LAP.
- 13.2 FOLLOWING THE PANEL INSTALLATION SEQUENCE AS OUTLINE IN SECTION 11.0 PANELS SHOULD BE STAGGERED. INSTALL THE PANEL FASTENERS AS DESCRIBED IN SECTION 12.0 EXCEPT FOR FASTENERS AT THE END LAP SUPPORT.
- 13.3 PRIOR TO PLACING THE UPPER ROW OF PANELS THE END LAPS OF THE LOWER PANELS MUST ALSO BE CAULKED. THE CAULKING ON THE END LAP SHOULD BE MARRIED TO THE CAULKING IN THE PANEL SIDE OVERLAP. PLACE CAULKING IMMEDIATELY PRIOR TO UPPER PANEL INSTALLATION.
- 13.4 NOTES:
 - 1) ALL SURFACES TO BE CAULKED MUST BE CLEAN AND DRY.
 - 2) APPLY END LAP SEAL TO PANEL SURFACE TO BE LAPPED.
 - 3) SEALANT STRIPS SHOULD OVERLAP ONE ANOTHER SIDE BY SIDE BUT NOT LESS THAN 1".

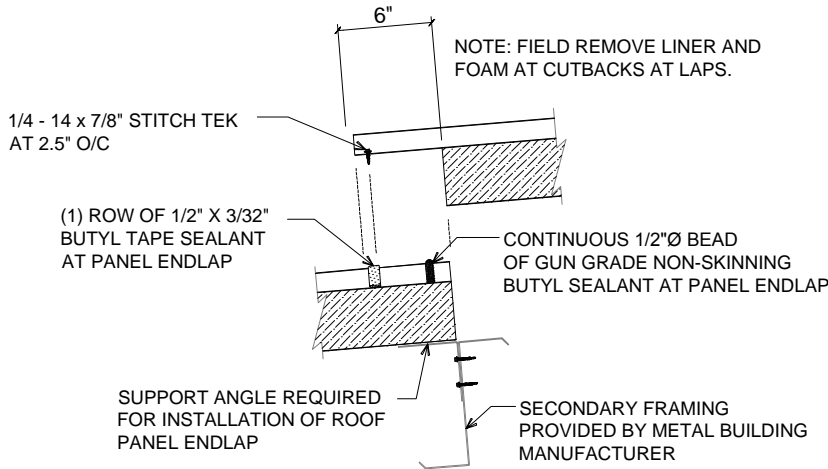

FIGURE 7

- 13.5 IF THE RIDGE CAP DETAIL IS TO BE USED THEN PLACE THE INSIDE RIDGE CAP AND CAULKING BEAD AS SHOWN ON ALL WEATHER INSULATED PANELS DRAWINGS. THE CAULKING BEAD SHOULD BE MARRIED TO THE BEAD IN THE OVERLAPPING RIB AS THE PANELS ARE SET IN PLACE.
- 13.6 ALL WEATHER INSULATED PANELS THAT INCORPORATE END LAPS WILL ARRIVE AT THE JOB SITE WITH THE FOAM AND LINER FACE IN PLACE. THE LINER FACE OF THE UPPER WILL HAVE A FACTORY SAW CUT 3", 4" TO 6" UP FROM THE END PANEL, (SEE FIGURE 8). REMOVED THE 3" TO 6" INCHES OF METAL AND FOAM AT THE END OF THE PANEL. CAREFULLY REMOVE ANY FOAM THAT REMAINS ON THE METAL SKIN TO INSURE A POSITIVE AIR AND WATER INFILTRATION SEAL.

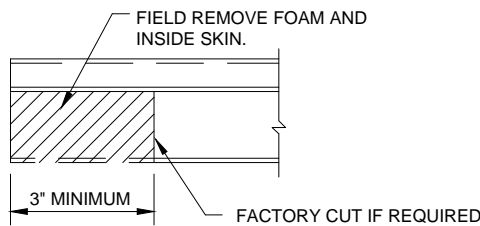

FIGURE 8

- 13.7 AFTER PLACING THE CAULK AND THE UPPER PANEL IS PREPPED, SET THE UPPER PANEL IN PLACE. INSTALL THE MAIN #14 SCREWS WITH SR CLIPS ON ALL SUPPORTS. IF THE RIDGE SUPPORT DOES NOT FALL UNDER THE APEX TRIM THEN FASTEN THE PANEL USING THE #14 SCREW AND SR CLIP AS USED ON TH.
- 17.8 ONCE THE UPPER PANEL IS IN PLACE AND FASTENED DOWN, FASTEN THE END LAP DOWN USING THE #14 X 7/8" STITCH TEK SCREW. THE SCREWS SHOULD BE PLACED IN THE LOCATIONS SHOWN ON ALL WEATHER INSULATED PANEL DRAWINGS THE SCREW SHOULD BE PLACED APPROXIMATELY 1" FROM THE END OF THE UPPER PANEL EXTERIOR FACING SO THAT IT PENETRATES THE CAULKING AND ACHIEVES FULL COMPRESSION OF THE FACINGS AT THE LAST ROW OF CAULKING.
- 13.9 REMOVE ALL METAL CHIPS AND FILINGS FROM THE DRILLING OF PILOT HOLES AND FASTENING OF THE PANELS IMMEDIATELY AFTER INSTALLATION. THESE FILINGS WILL RUST AND CORRODE THE PANEL SURFACE.
- 13.10 PROCEED TO THE NEXT PANEL AND REPEAT STEPS 13.2 THRU 13.9
- 13.11 AFTER ALL PANELS ARE INSTALLED FASTEN THE EAVE, RAKE AND PEAK TRIM RESPECTIVELY. THE TRIM SHOULD BE FASTENED AS SHOWN ON ALL WEATHER INSULATED PANEL DETAILS.

SHEET

7 OF 9

DATE: 09/08/11

DRAWN BY: CLR / JRM

**SR2-SR3 INSULATED ROOF PANELS
GENERAL INSTALLATION GUIDE**

929 ALDRIDGE ROAD
VACAVILLE, CA 95688
PHONE: (707) 359-2280
FAX: (707) 359-2286
WWW.AWIPANELS.COM

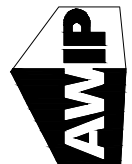

ALL WEATHER INSULATED PANELS

GENERAL INSTALLATION GUIDE continued

14.0 PEAK TRIM INSTALLATION STEPS

- 14.1 THROUGH FASTEN THE ROOF PANELS AT THE RIDGE AS SHOWN ON ALL WEATHER INSULATE PANEL DETAILS. IF THE FASTENERS DO NOT FALL UNDER THE PEAK TRIM THEN USE THE #14 TYPE THROUGH FASTENER AND SADDLE WASHER CLIP AND FASTEN SIMILAR TO THE INTERMEDIATE RIBS AT THREE FASTENERS PER PANEL.
- 14.2 TEMPORARILY SET THE PEAK TRIM IN PLACE TO DETERMINE THE LOCATION OF THE CAULKING AND CLOSURE STRIPS. RUN A LINE OR SNAP A CHALK LINE ALONG THE LENGTH OF THE APEX TRIM FOR PROPER PLACEMENT OF THE CAULKING AND CLOSURE STRIPS.
- 14.3 APPLY BUTYL TAPE ONTO THE PANEL PROFILE AS SHOWN ON ALL WEATHER INSULATED PANEL DETAILS IN PREPARATION FOR THE CLOSURE STRIP. ALL SURFACES TO RECEIVE CAULK AND CLOSURE STRIPS.
- 14.4 SEAT THE CLOSURE STRIP FIRMLY INTO THE BUTYL TAPE TO INSURE A CONTINUOUS SEAL. IF VOIDS EXIST ADD ADDITIONAL BUTYL SEALANT CAULK AND RESEAT THE CLOSURE CORRECTLY.
- 14.5 PLACE BUTYL TAPE ON THE CLOSURE STRIP AND PLACE THE APEX TRIM AS SHOWN ON ALL WEATHER STANDARD APEX DETAIL. FASTEN THE APEX TRIM AT EACH HI RIB WITH A #14 X 7/8" STITCH TEK SCREW. AT THE END OF THE APEX TRIM PLACE TWO BEADS OF THE CAULK OR TAPE 2" FROM THE END AND OVERLAP THE NEXT APEX TRIM APPROXIMATELY 4". FASTEN THE OVERLAPS DOWN WITH #14 X 7/8" STITCH TEK LAP SCREWS AS REQUIRED.
- 14.6 IMMEDIATELY REMOVE ANY METAL CHIPS OR FILINGS LEFT FROM THE SCREWS OR SHEET METAL FABRICATION AS THEY RUST AND CORRODE THE PANEL SURFACE.

15.0 MISCELLANEOUS INFORMATION

- 15.1 TO PREVENT GALVANIC ACTION, ISOLATE ANY ALUMINUM TRIM SURFACES FROM SURFACE OF PANEL SUPPORT STEEL USING ONE OF THE FOLLOWING METHODS:
 - 1) AN APPROVED SEALANT OR SEALANT TAPE.
 - 2) A NONABSORBENT GASKET.
 - 3) A DUCT TAPE OR EQUIVALENT TYPE TAPE.
 - 4) PAINT THE INCOMPATIBLE METAL WITH A COATING OF HEAVY BODIED BITUMINOUS PAINT.
- 15.2 GAS BUBBLES ON FOAM PANELS ARE AN INDUSTRY-WIDE, SPORADIC PROBLEM. IF THEY OCCUR ON THIS PROJECT, THEY CAN EASILY BE REPAIRED BY DRILLING A 1/16" DIAMETER BY 1 3/4" DEEP HOLE NEAR THE BOTTOM OF THE GAS BUBBLE IN THE EXTERIOR METAL FACING ALLOW THE TRAPPED GAS TO BE RELEASED. THE REPAIR IS COMPLETED BY APPLYING A SMALL AMOUNT OF TOUCH-UP PAINT TO THE RAW EDGE OF THE DRILL HOLE. GAS BUBBLES SHOULD BE REPAIRED AS SOON AS POSSIBLE SINCE THEY WILL CONTINUE TO ENLARGED UNTIL CORRECTED.

16.0 EXPOSURE TO HEAT OR FLAME

- 16.1 ALTHOUGH AWIP URETHANE CORE PANELS ARE ACCEPTABLE FOR USE IN NO-COMBUSTIBLE BUILDING ASSEMBLIES IN ACCORDANCE WITH INTERNATIONAL BUILDING CODE (IBC) AND HAVE BEEN EXHAUSTIVELY TESTED FOR FIRE RESISTIVITY BASED ON THEIR END USE, THEY ARE NOT NON-COMBUSTIBLE IN AND OF THEMSELVES. THEY ARE NOT "FIRE RATED" PER ASTM E119. THEREFORE, THEY SHALL NOT BE EXPOSED TO EXTREME HIGH TEMPERATURES OR DIRECT FLAME AT ANY TIME. IN SIMPLE TERMS, DON'T USE A WELDING TORCH ON OR NEAR INSULATED PANELS ANY MORE THAN YOU WOULD ON A WOOD BUILDING ASSEMBLY. REFER TO PANEL TEST DATA INFORMATION UNDER "FIRE" FOR DETAILED INFORMATION ON IGNITION, HEAT OF COMBUSTION AND SURFACE BURNING.

17.0 CLEANING PANELS

- 17.1 AFTER INSTALLATION, SURFACES MUST BE CLEANED TO REMOVE ANY METAL CHIPS TO PREVENT ANY POSSIBLE OXIDATION. A WET, SOFT CLOTH IS RECOMMENDED.

18.0 MAINTENANCE

- 18.1 PROPER INSTALLATION AND MAINTENANCE ARE EXTREMELY IMPORTANT TO OBTAIN THE BEST PERFORMANCE AND APPEARANCE FROM THE INSULATED PANEL.
- 18.2 DIRT, OIL, GREASE, FINGERPRINTS OR ANY OTHER KIND OF CONTAMINANT MUST BE COMPLETELY REMOVED WHEN THE INSTALLATION IS FINISHED TO MAXIMIZE COATINGS PERFORMANCE.
- 18.3 THE BUILDING WILL REQUIRE PERIODIC MAINTENANCE ACCORDING TO CONDITIONS AT THE SITE: U.V., DIRT, SMOKE, CORROSIVE ATMOSPHERE, ECT. IF FURTHER ASSISTANCE IS REQUIRED, PLEASE CONSULT THE TECHNICAL DEPARTMENT OF ALL WEATHER INSULATED PANELS.
- 18.4 TO REMOVE SUPERFICIAL OXIDATION AND TOUGH STAINS, IT IS RECOMMENDED TO USE A REGULAR HOUSEHOLD CLEANER FOLLOWED BY A THROUGH RINSING. WIRE BRUSHED OR AN ABRASIVE MATERIAL WILL DAMAGE THE PAINTED COATING.
- 18.5 IF "TOUCH-UP" PAINT IS REQUIRED, CONTACT ALL WEATHER INSULATED PANELS TO OBTAIN AN AIR-DRY URETHANE COLOR MATCH FOR YOUR PROJECT.

SHEET

8 OF 9

DATE: 09/08/11

DRAWN BY: CLR / JRM

SR2-SR3 INSULATED ROOF PANELS GENERAL INSTALLATION GUIDE

929 ALDRIDGE ROAD
VACAVILLE, CA 95688
PHONE: (707) 359-2280
FAX: (707) 359-2286
WWW.AWIPANELS.COM



ALL WEATHER INSULATED PANELS

SR2-SR3 INSULATED ROOF PANELS GENERAL INSTALLATION GUIDE

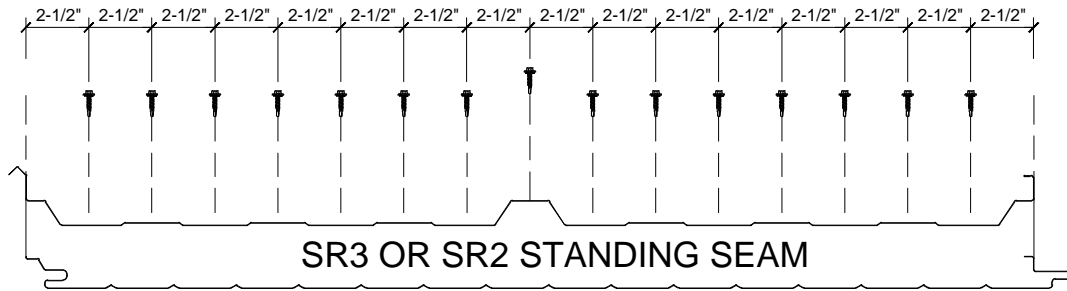
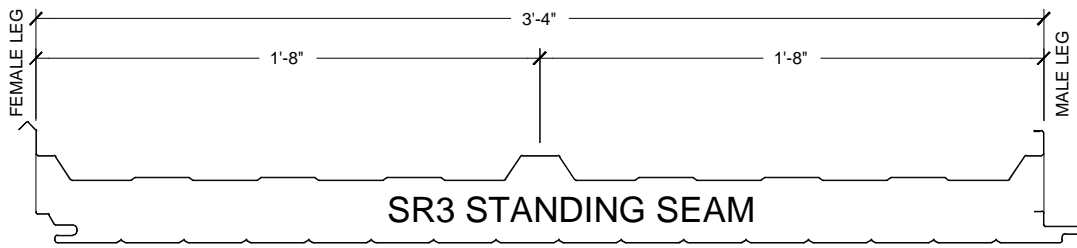
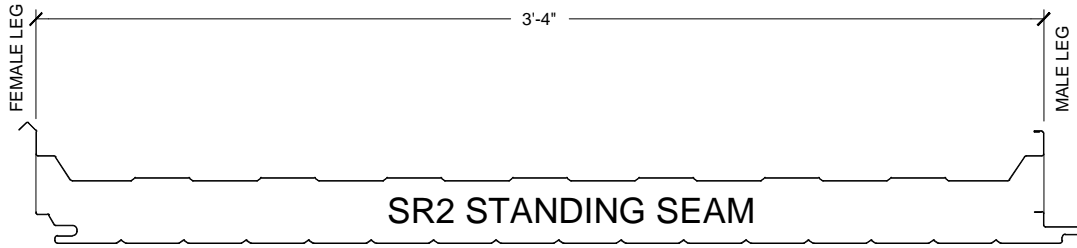

STITCH TEK PATTERN AT PANEL END LAP

929 ALDRIDGE ROAD
VACAVILLE, CA 95688
PHONE: (707) 359-2280
FAX: (707) 359-2286
WWW.AWIPANELS.COM

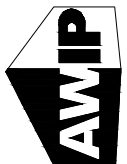

ALL WEATHER INSULATED PANELS